

NOTES:

- 1.) Post size depends on fence height and wind loads. See MONTAGE PLUS™ specifications for post sizing chart.
- 2.) Third rail required for Double Rings.
- 3.) Available in 3" air space and/or Flush Bottom on most heights.

RAKING DIRECTIONAL ARROW
Welded panel can be raked 30" over 8' with arrow pointing down grade.

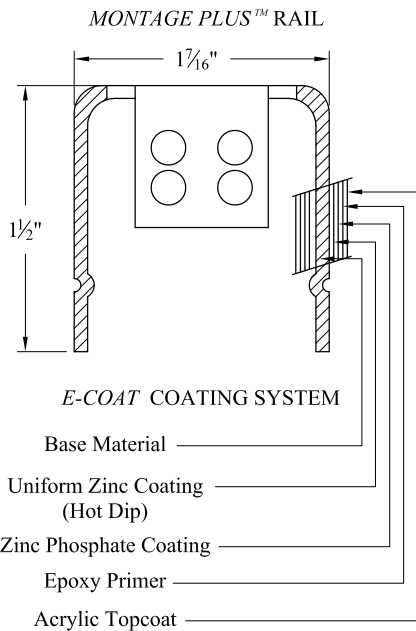

PROFUSION™ WELDING PROCESS

No exposed welds,
Good Neighbor profile - Same appearance on both sides

MONTAGE PLUS™ RAIL
Specially formed high strength architectural shape.

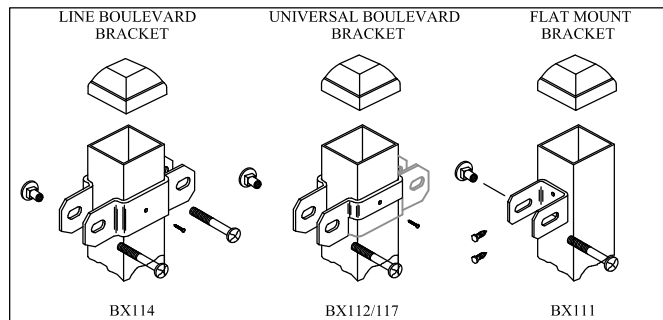

COMMERCIAL STRENGTH WELDED STEEL PANEL
PRE-ASSEMBLED

Title: **MONTAGE PLUS CLASSIC 2/3-RAIL**

DR: CI SH . 1 of 1 SCALE: DO NOT SCALE

CK: ME Date 7/20/09 REV: d



AMERISTAR®

1555 N. Mingo
Tulsa, OK 74116
1-888-333-3422
www.ameristarfence.com