

NOTES:

- 1.) Post size depends on fence height and wind loads. See *MONTAGE PLUS™* specifications for post sizing chart.
- 2.) Third rail required for *Double Rings*.
- 3.) Available in 3" air space and/or Flush Bottom on most heights.

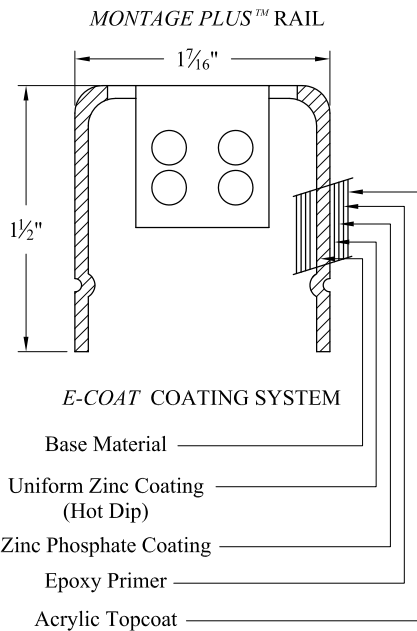

**COMMERCIAL STRENGTH WELDED STEEL PANEL
PRE-ASSEMBLED**

RAKING DIRECTIONAL ARROW
Welded panel can be raked 30" over 8' with arrow pointing down grade.

PROFUSION™ WELDING PROCESS
No exposed welds,
Good Neighbor profile - Same appearance on both sides

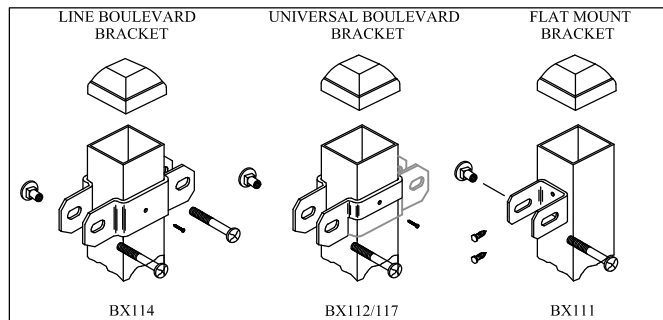
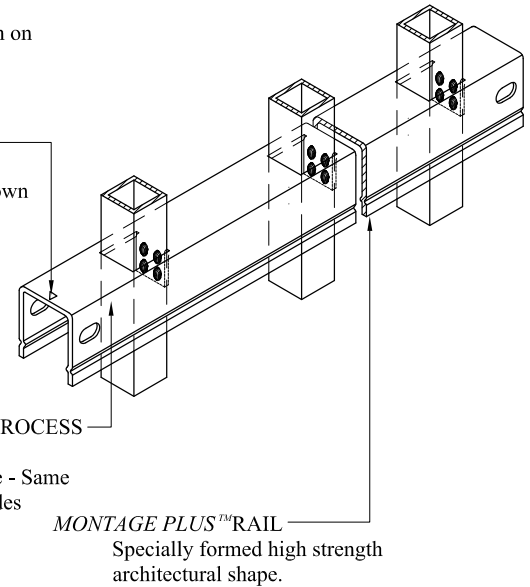

Title: MONTAGE PLUS MAJESTIC 2/3-RAIL			
DR: CI	SH . 1 of 1	SCALE: DO NOT SCALE	
CK: ME	Date 7/20/09	REV: d	



AMERISTAR®

1555 N. Mingo
Tulsa, OK 74116
1-888-333-3422
www.ameristarfence.com